

REVISION	DATE	PORTER No.
CUSTOMER No.	DATE	

00790-100 and 00790-200  
FLOOR SLEEVES FOR 3" DIA. POST  
WITH 5" DIA. COVER

**Porter**  
WORLD LEADER  
IN QUALITY SPORTS EQUIPMENT  
2500 S. 25th AVENUE  
BROADVIEW, ILLINOIS 60155  
www.porter-ath.com

DRAWING BY  
ME  
CHECKED BY  
RJM  
PAGE No.  
G-790

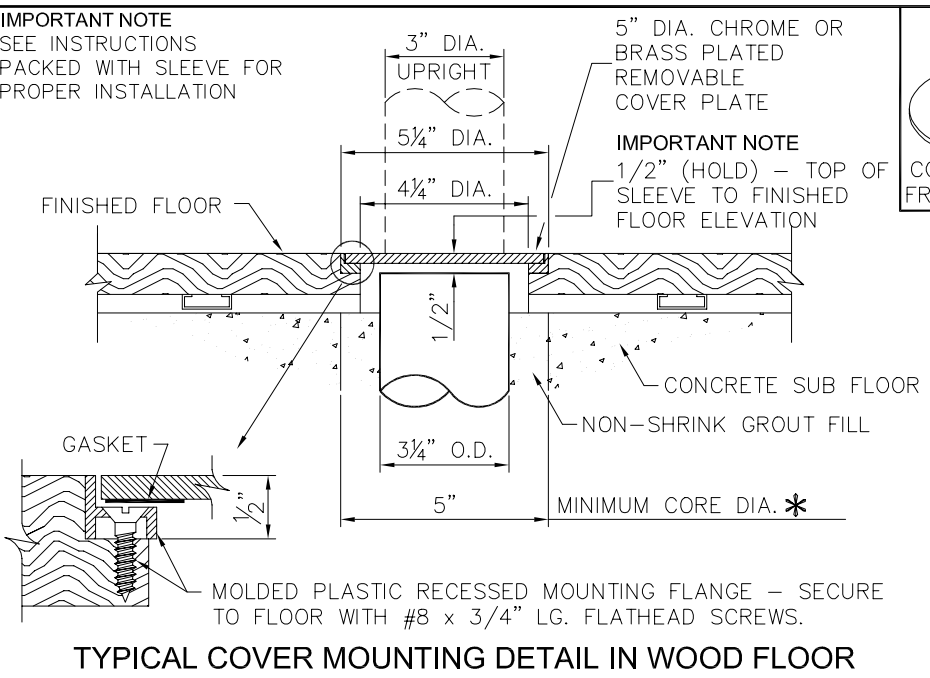

**TYPICAL COVER MOUNTING DETAIL IN WOOD FLOOR**

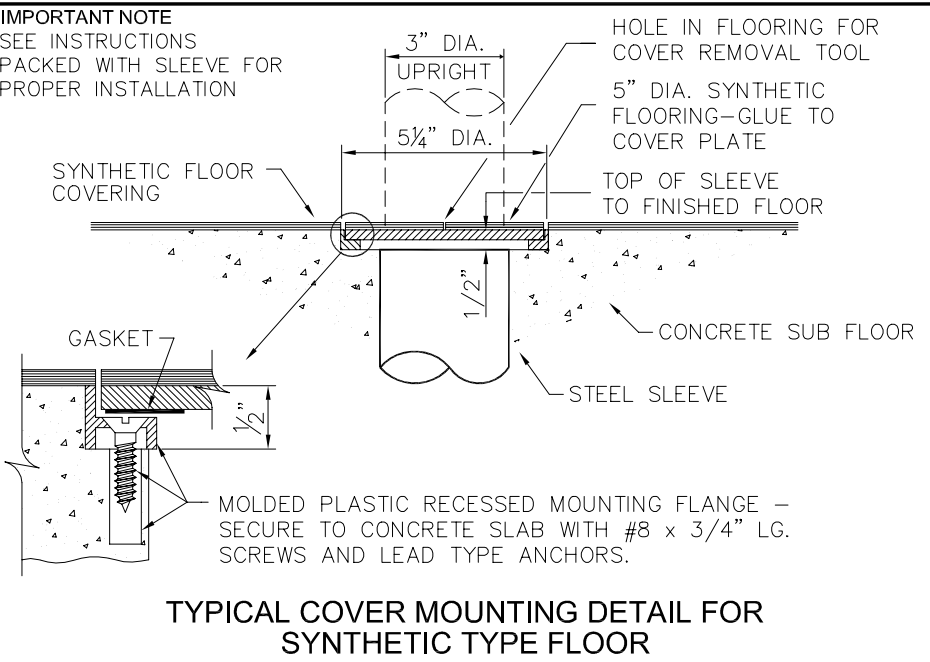

**TYPICAL COVER MOUNTING DETAIL FOR  
SYNTHETIC TYPE FLOOR**

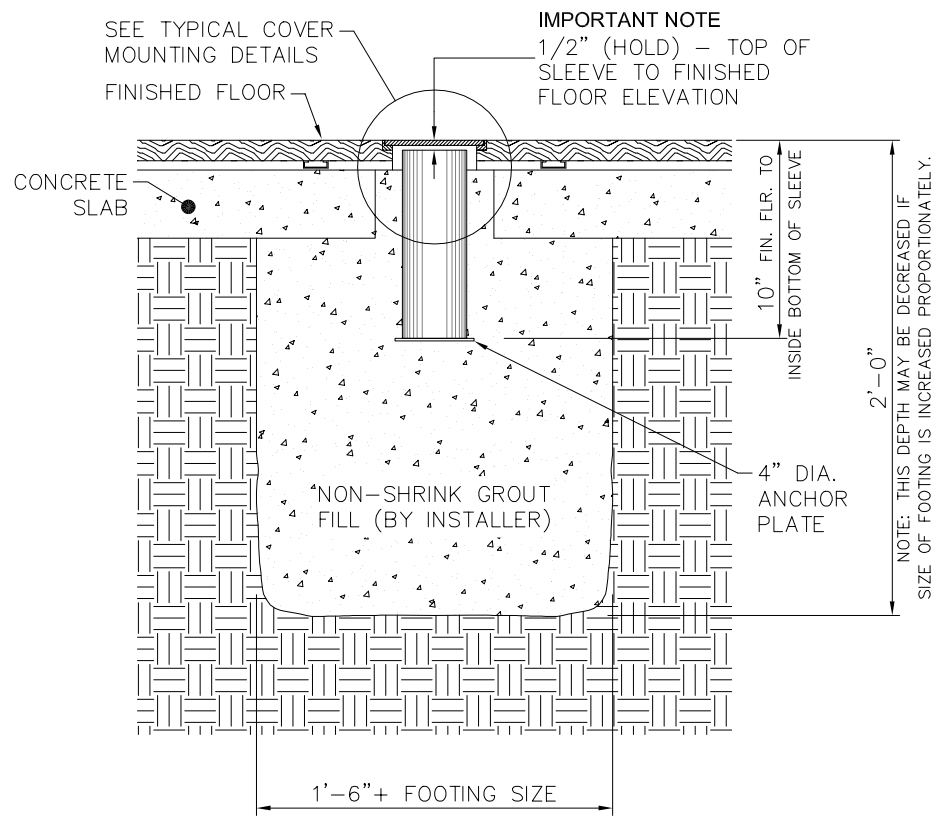
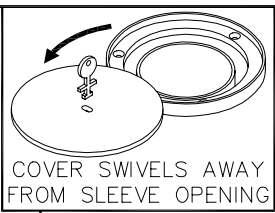

**TYPICAL INSTALLATION DETAIL**

**INSTALLATION OPTIONS** (NOTE - SLEEVE SHOULD BE INSTALLED IN SLAB  
BEFORE FINISHED FLOOR IS IN PLACE. IF FINISHED FLOOR IS IN PLACE,  
USE FLOOR SLEEVE WITH 8" COVER - SEE PAGE G-792.)

\*1. LOCATE AND CORE 5" MINIMUM DIA. HOLES IN SLAB AND GROUT  
SLEEVES IN PLACE PER DETAIL ABOVE. **CAUTION** - BEFORE CORING  
HOLES IN EXISTING CONCRETE SLAB, CHECK FOR LOCATIONS OF  
ELECTRICAL CONDUIT OR PIPE.

2. LOCATE SLEEVES AND POUR IN PLACE IN CONCRETE SLAB.  
COMPLETE INSTALLATION INSTRUCTIONS ARE INCLUDED WITH FLOOR SLEEVE.

INDICATE QUANTITY OF FLOOR SLEEVES REQ'D

SELECT COVER:

00790-100 FLOOR SLEEVE WITH CHROME COVER PLATE

00790-200 FLOOR SLEEVE WITH BRASS COVER PLATE

# **SPECIFICATIONS**

## **PORTER No. 00790-100 GYMNASIUM FLOOR SLEEVE WITH CHROME COVER FOR 3" (7.6cm) O.D. VOLLEYBALL STANDARDS**

Sleeve shall be cast in concrete footing before concrete slab is poured. (For installation in existing floors, specify the use of No. 00792-100 or 00792-200 sleeve.) Top of sleeve to be installed 1/2" (1.3cm) below finished floor elevation.

Chrome plated cover plate assembly shall be provided for use in either synthetic or wood floors. Cover plate shall consist of molded plastic recessed mounting flange, cork gasket and a 5" (12.7cm) diameter chrome plated cover. Cover shall be equipped with a swivel type retainer pin to prevent theft. Special key shall be provided for cover removal.

Sleeve assembly shall be 3-1/4" (8.3cm) O.D. heavy wall steel tubing extending 10" (25.4cm) into concrete footing. Bottom of sleeve shall be capped with a 4" (10.2cm) diameter steel disc to provide proper anchorage in footing. Sleeve assembly to be finished in a rust resistant enamel finish.

## **PORTER No. 00790-200 GYMNASIUM FLOOR SLEEVE WITH BRASS COVER FOR 3" (7.6cm) O.D. VOLLEYBALL STANDARDS**

Same specification as No. 00790-100 above, except that cover plate is brass plated.